

MHCP Stainless Steel Heavy-Duty Cartridge Primary Cleaner

Massive, Rugged, Ready to Work

The MHCP Heavy-Duty Cartridge Primary Cleaner features segmented SuperShear™ blades (Optional FRAS-approved blades) that are engineered to stand up to the most abusive beltline conditions, such as wet, sticky clay, and maintain constant cleaning force. The massive blades have an extended wear life and also a quick-change blade cartridge feature. This is an extreme-duty cleaner that gets the job done – and with minimal maintenance.

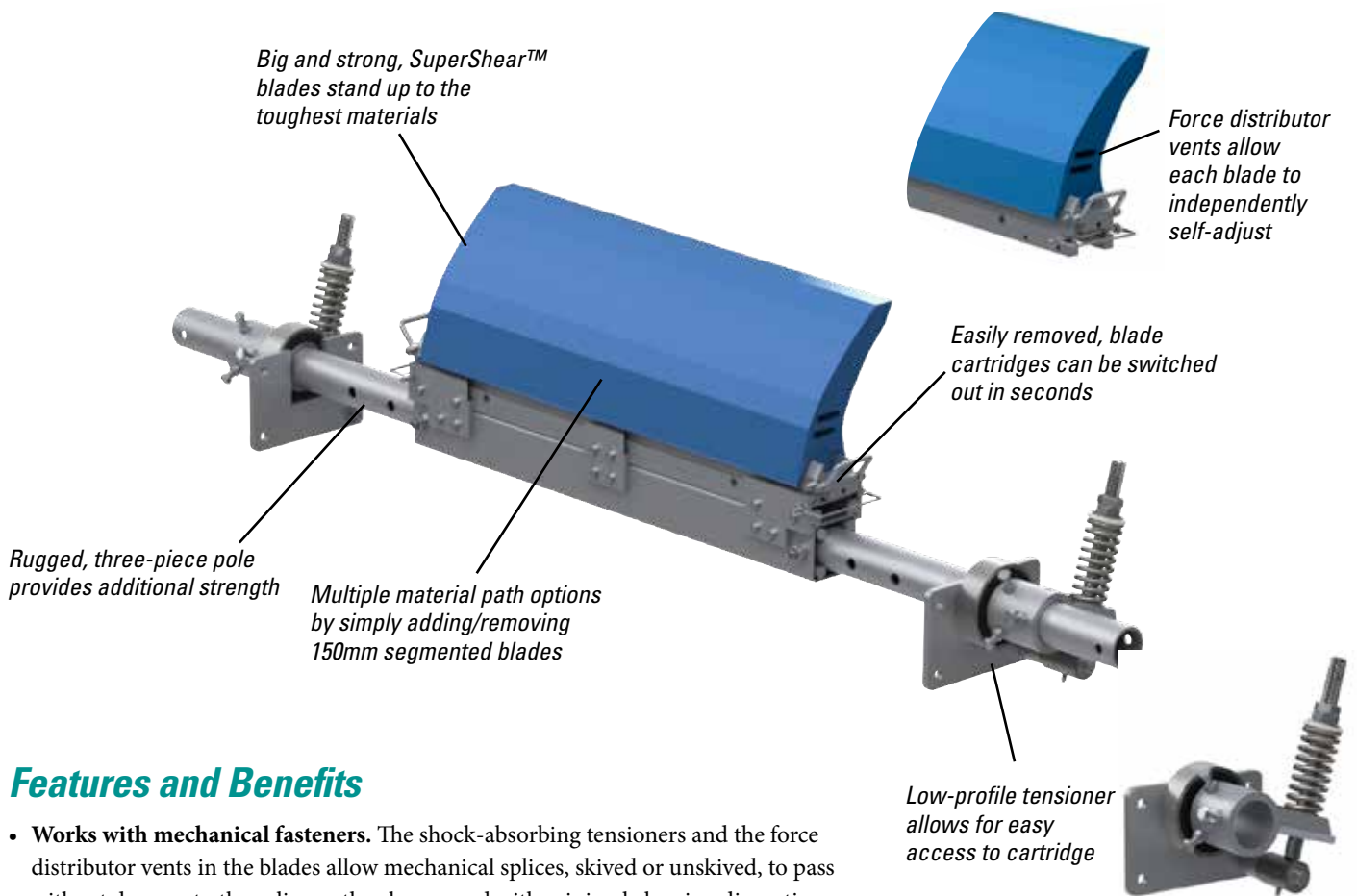

Features and Benefits

- **Works with mechanical fasteners.** The shock-absorbing tensioners and the force distributor vents in the blades allow mechanical splices, skived or unskived, to pass without damage to the splice or the cleaner and with minimal cleaning disruption.
- **Complete cleaning system.** When teamed with the MHS HD Secondary Cleaner, it makes up a system that delivers maximum cleaning power for the most abusive conveyor applications.
- **Made for mining conveyors.** Made from heavy-duty, corrosion-resistant steel, the MHCP is available in sizes for belt widths from 600 to 2100mm. Additional sizes are available upon request.
- **Stainless steel.** Corrosive environments wear on any component, but stainless steel can protect against that.

MHCP Stainless Steel Heavy-Duty Cartridge Primary Cleaner

Maximum Belt Speed

6 M/sec

Temperature Rating

-35° C to 82° C

Minimum Pulley Diameter

500 mm

Blade Height

350 mm

Usable Blade Wear Length

200 mm

Blade Material

Urethane 90 durometer (proprietary blend for abrasion resistance and long wear)

Available for Belt Widths

600 to 2100 mm

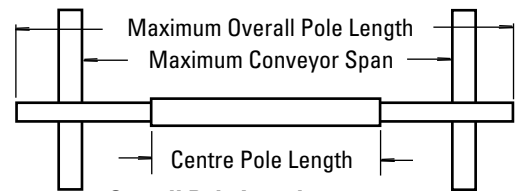

Overall Pole Length

Cleaner size + 1425 mm

Maximum Conveyor Span

Cleaner size + 1050 mm

Ordering Information

MHCP Stainless Steel Primary Cleaner with PST			
Belt Width	Blade Coverage	Ordering Number	Item Code
mm	mm		
600	450	MHCP-600S-S/S	61504
750	600	MHCP-750S-S/S	61505
900	750	MHCP-900S-S/S	61506
1050	900	MHCP-1050S-S/S	61507
1200	1050	MHCP-1200S-S/S	61508
1350	1200	MHCP-1350S-S/S	61509
1500	1350	MHCP-1500S-S/S	61510
1650	1500	MHCP-1650S-S/S	61511
1800	1650	MHCP-1800S-S/S	61512
2100	1950	MHCP-2100S-S/S	61513

Cartridge Kits (Includes Cartridge and mounting bolts)		
Belt Width	Ordering Number	Item Code
mm		
600	MHCP-S/S-CK600	61535
750	MHCP-S/S-CK750	61536
900	MHCP-S/S-CK900	61537
1050	MHCP-S/S-CK1050	61538
1200	MHCP-S/S-CK1200	61539
1350	MHCP-S/S-CK1350	61540
1500	MHCP-S/S-CK1500	61541
1650	MHCP-S/S-CK1650	61542
1800	MHCP-S/S-CK1800	61543
2100	MHCP-S/S-CK2100	61544

NOTE: For easy blade changeout, remove cartridge with worn blades and replace with new blade cartridge kit. New blades can then be installed in the old cartridge for the next changeout.

MHCP Stainless Steel Primary Cleaner with PST and FRAS Blades			
Belt Width	Blade Coverage	Ordering Number	Item Code
mm	mm		
600	450	MHCP-600S-S/S-FR	61624
750	600	MHCP-750S-S/S-FR	61625
900	750	MHCP-900S-S/S-FR	61626
1050	900	MHCP-1050S-S/S-FR	61627
1200	1050	MHCP-1200S-S/S-FR	61628
1350	1200	MHCP-1350S-S/S-FR	61629
1500	1350	MHCP-1500S-S/S-FR	61630
1650	1500	MHCP-1650S-S/S-FR	61631
1800	1650	MHCP-1800S-S/S-FR	61632
2100	1950	MHCP-2100S-S/S-FR	61633

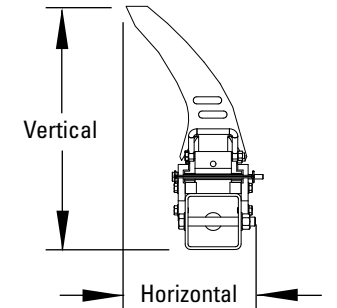

Horizontal Clearance Required
175 mm

Vertical Clearance Required
475 mm

Pole Location Chart			
A	X	Y	C
500	229	414	473
525	242	414	479
550	254	414	486
575	267	414	492
600	279	414	499
625	292	414	506
650	304	414	514
675	317	414	521
700	329	414	529
725	342	414	537
750	354	414	545
775	367	414	553
800	379	414	561
825	392	414	570
850	404	414	578
875	417	414	587
900	429	414	596
925	442	414	605
950	454	414	614
975	467	414	624
1000	479	414	633
1025	492	414	643
1050	504	414	652
1075	517	414	662
1100	529	414	672
1125	542	414	682
1150	554	414	692
1175	567	414	702
1200	579	414	712

Pole Location Specs

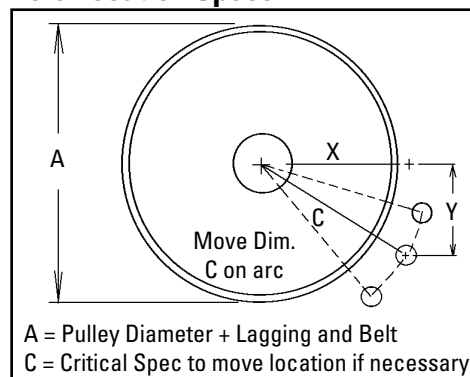

Flexco (Aust.) Pty. Ltd • 10 Solent Circuit • Baulkham Hills NSW 2153 • Australia
Tel: 612-8818-2000 • Fax: 612-8824-6333 • E-mail: sales@flexco.com.au • Web: www.flexco.com

Chile: 56-2-8967870 • China: 86-21-33528388 • England: 44-1274-600-942
Germany: 49-7428-9406-0 • India: 91-44-4354-2091 • Mexico: 52-55-5674-5326
Singapore: 65-6281-7278 • South Africa: 27-11-608-4180 • USA: 1-630-971-0150

©2012 Flexible Steel Lacing Company, 10/12, X3026

Authorized Distributor:

